

Figure 24. Mass spectrum of compound 81

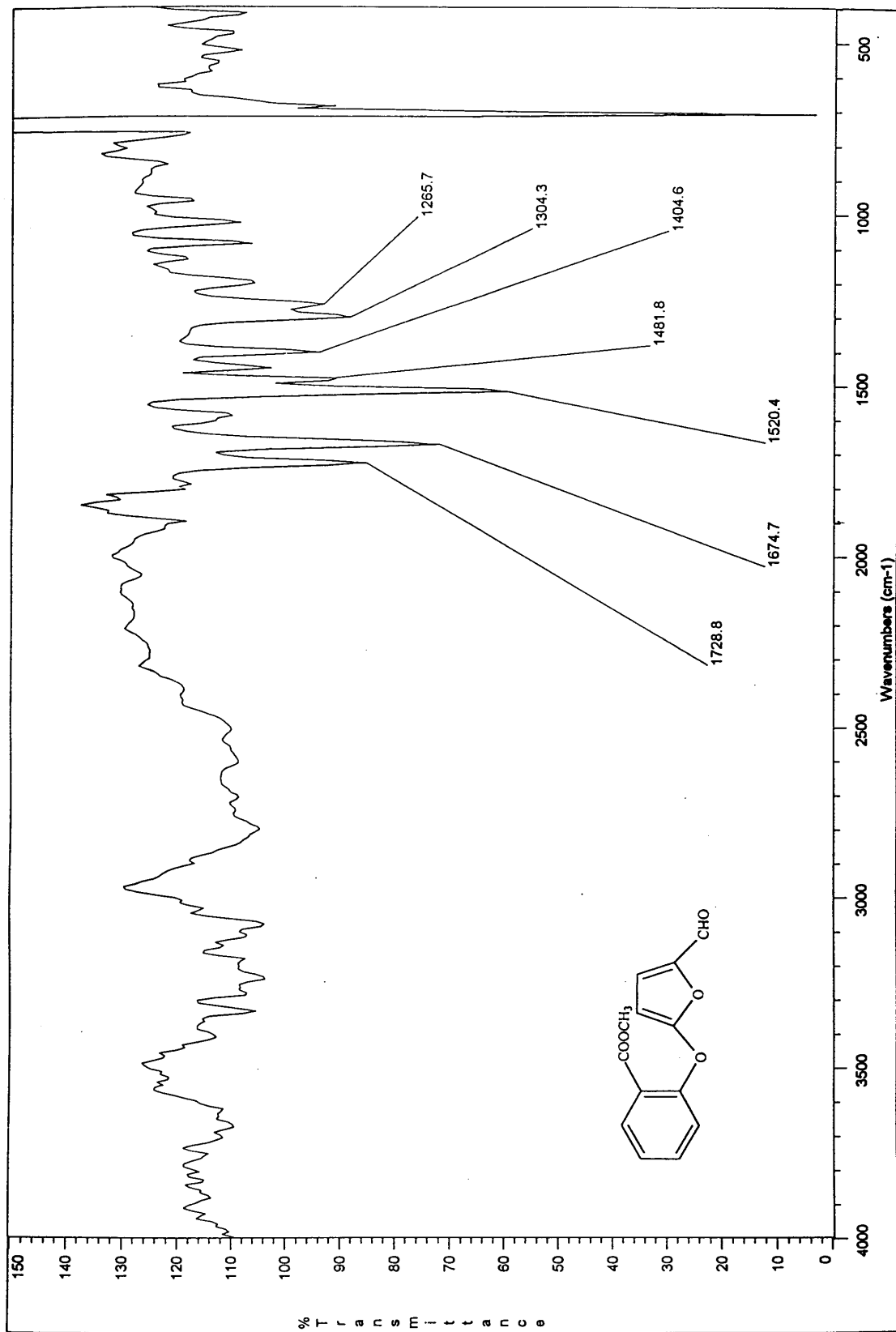

Figure 25. IR spectrum of compound 81

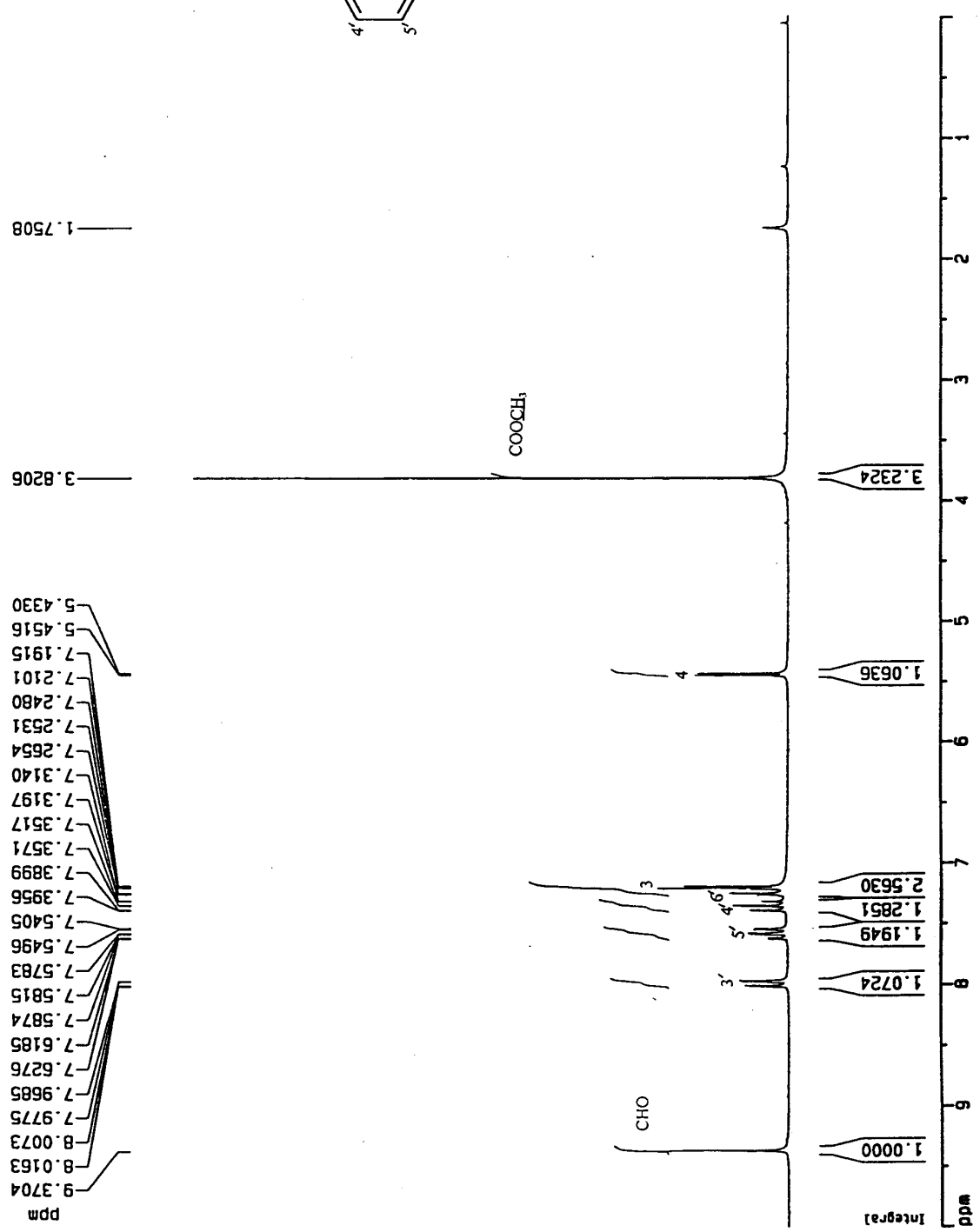
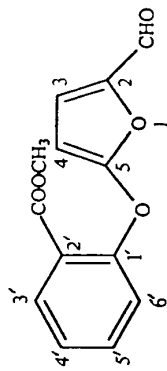

Figure 26. ¹H-NMR spectrum of compound 81

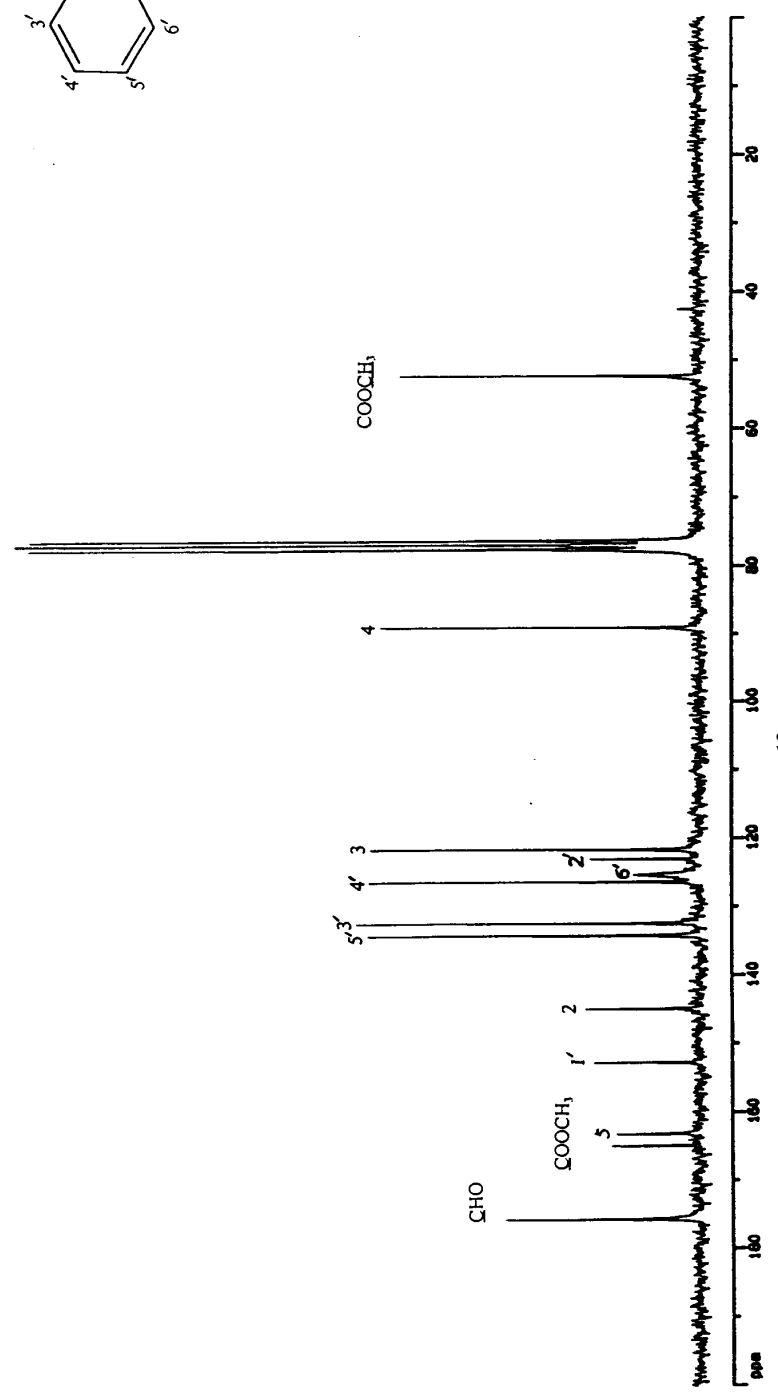
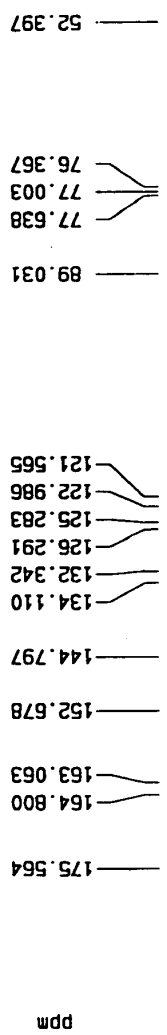
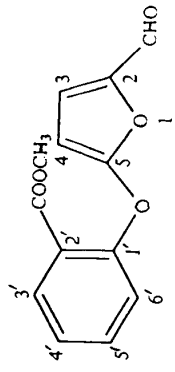

Figure 27. ¹³C-NMR spectrum of compound 81

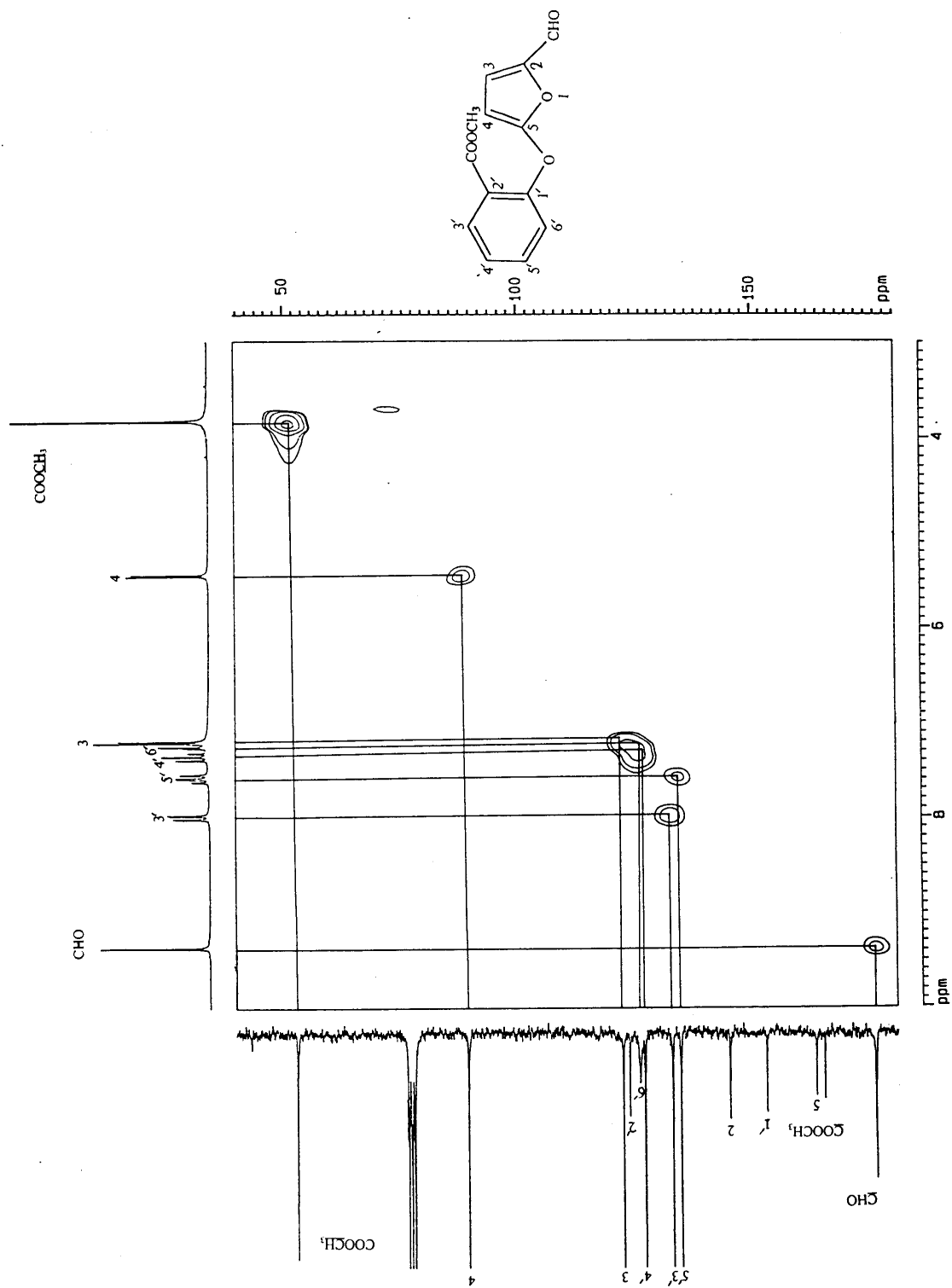

Figure 28. HMBC spectrum of compound 81

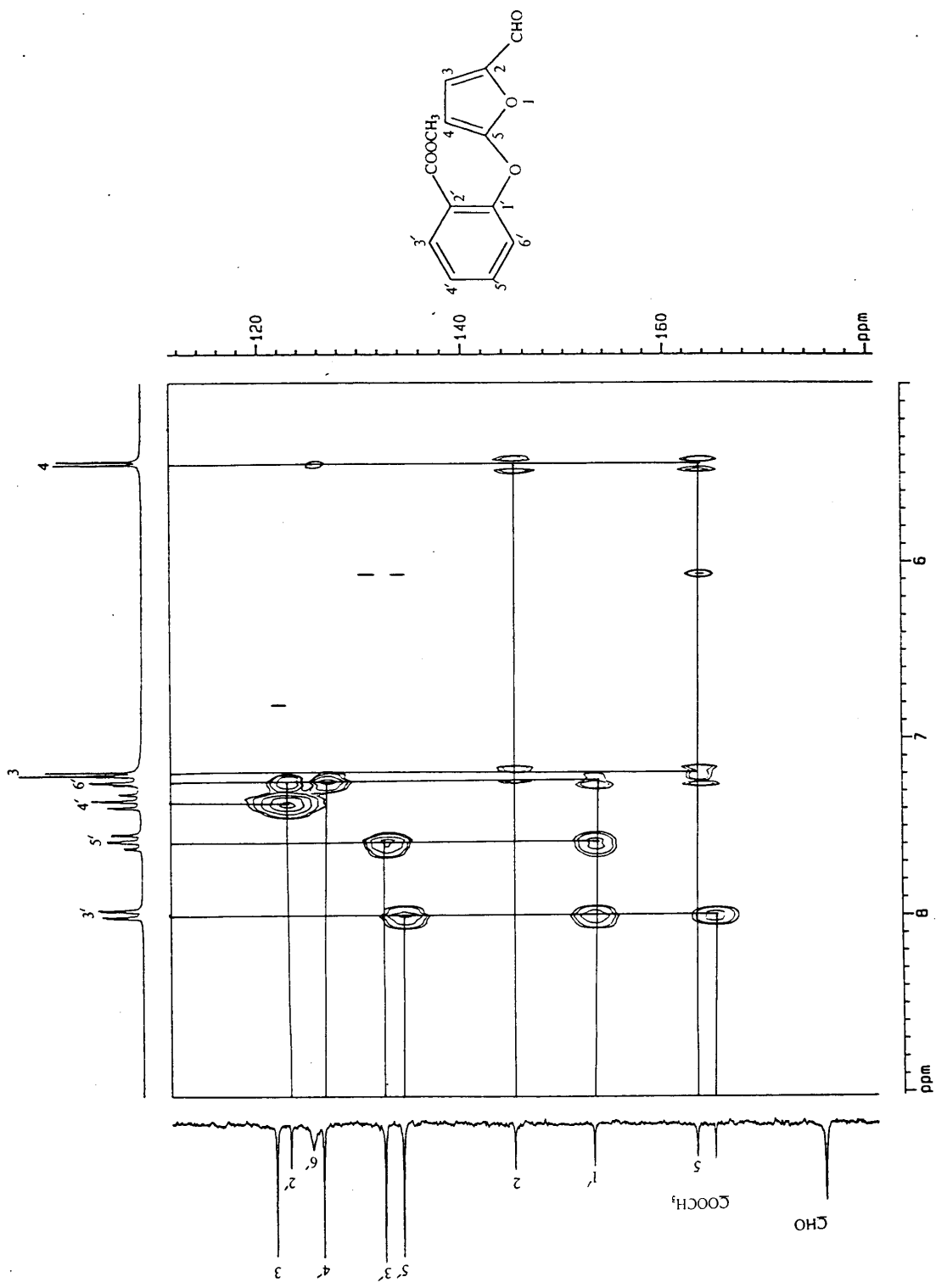

Figure 29. HMBC spectrum of compound 81

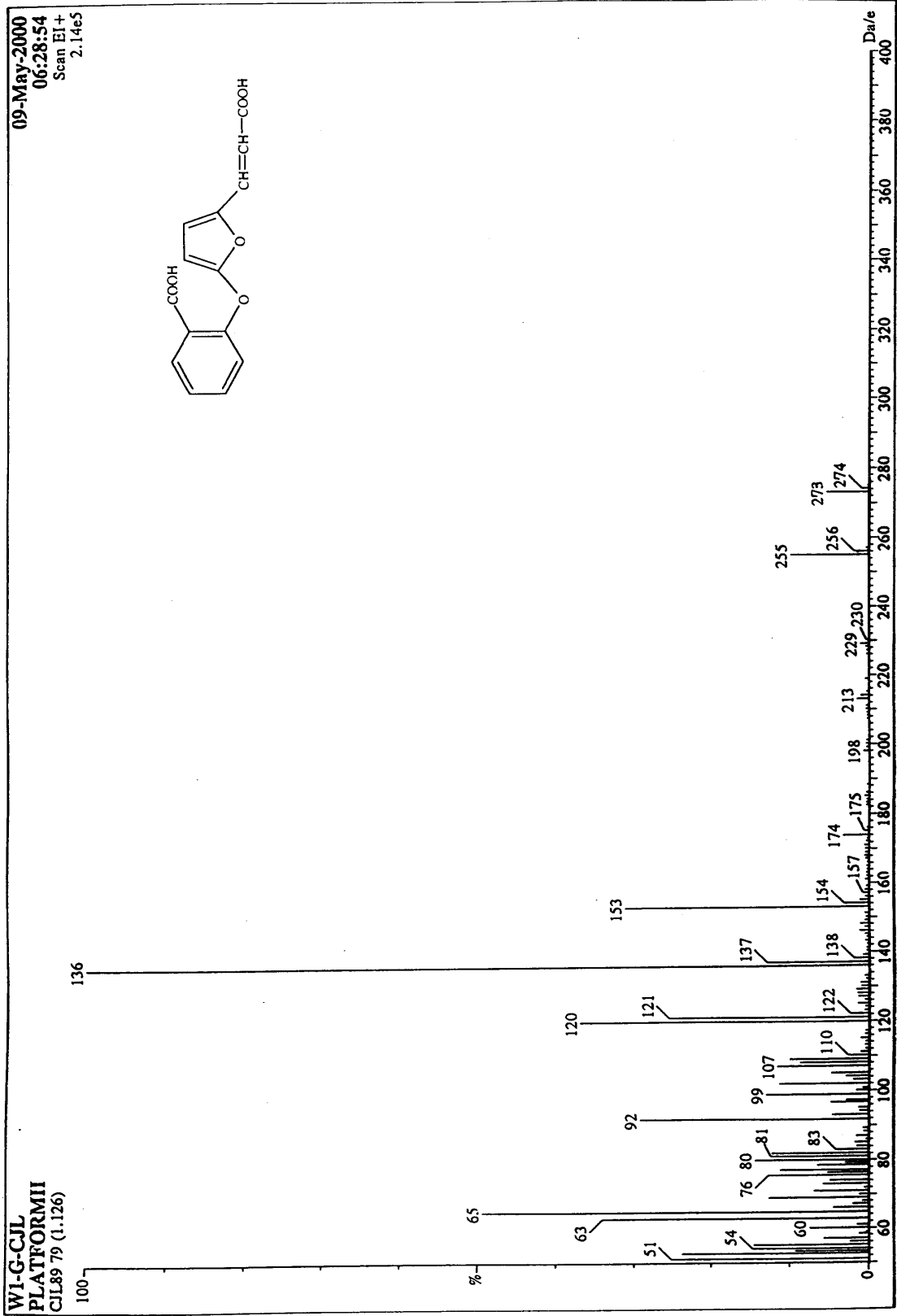

Figure 30. Mass spectrum of compound 111

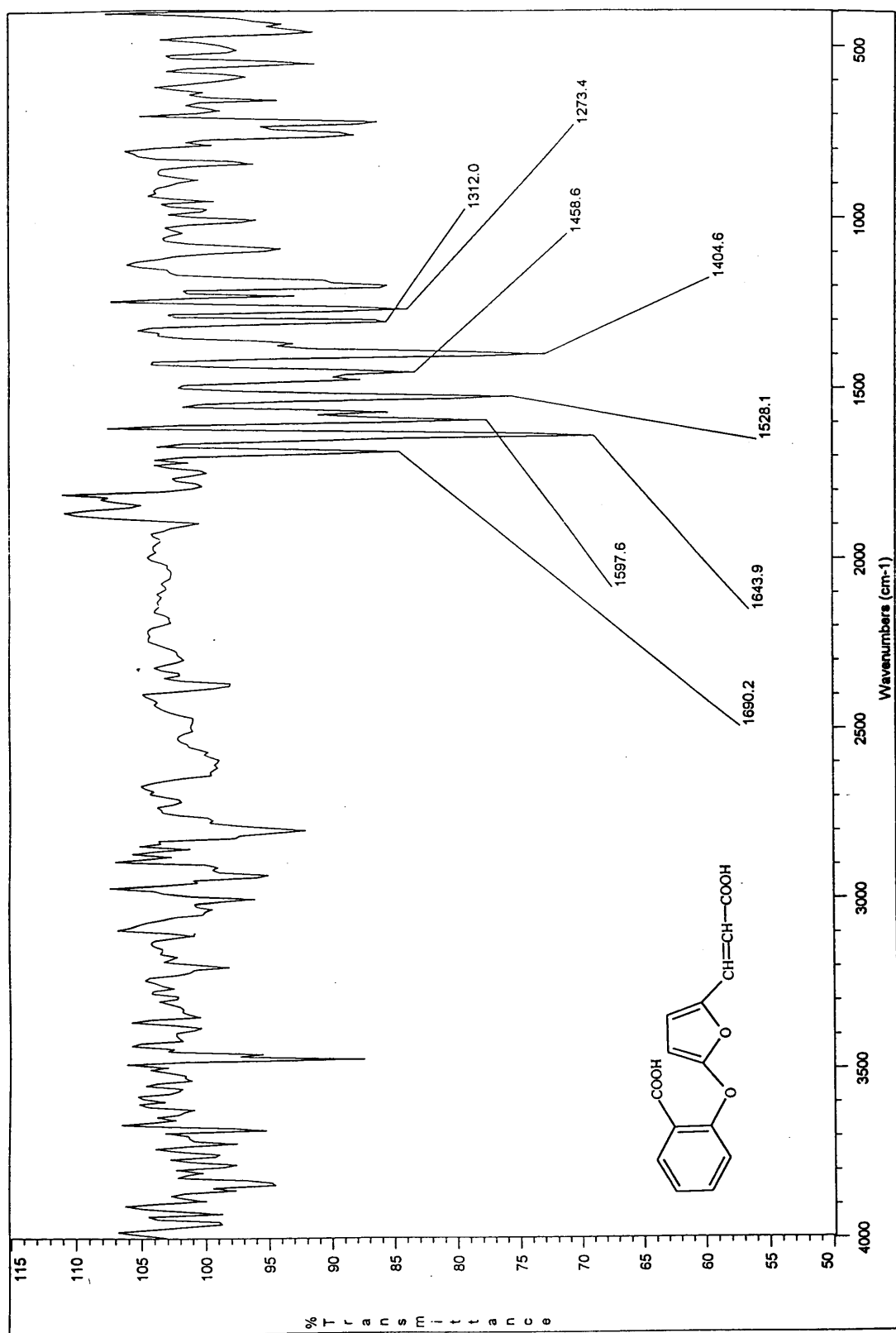

Figure 31. IR spectrum of compound 111

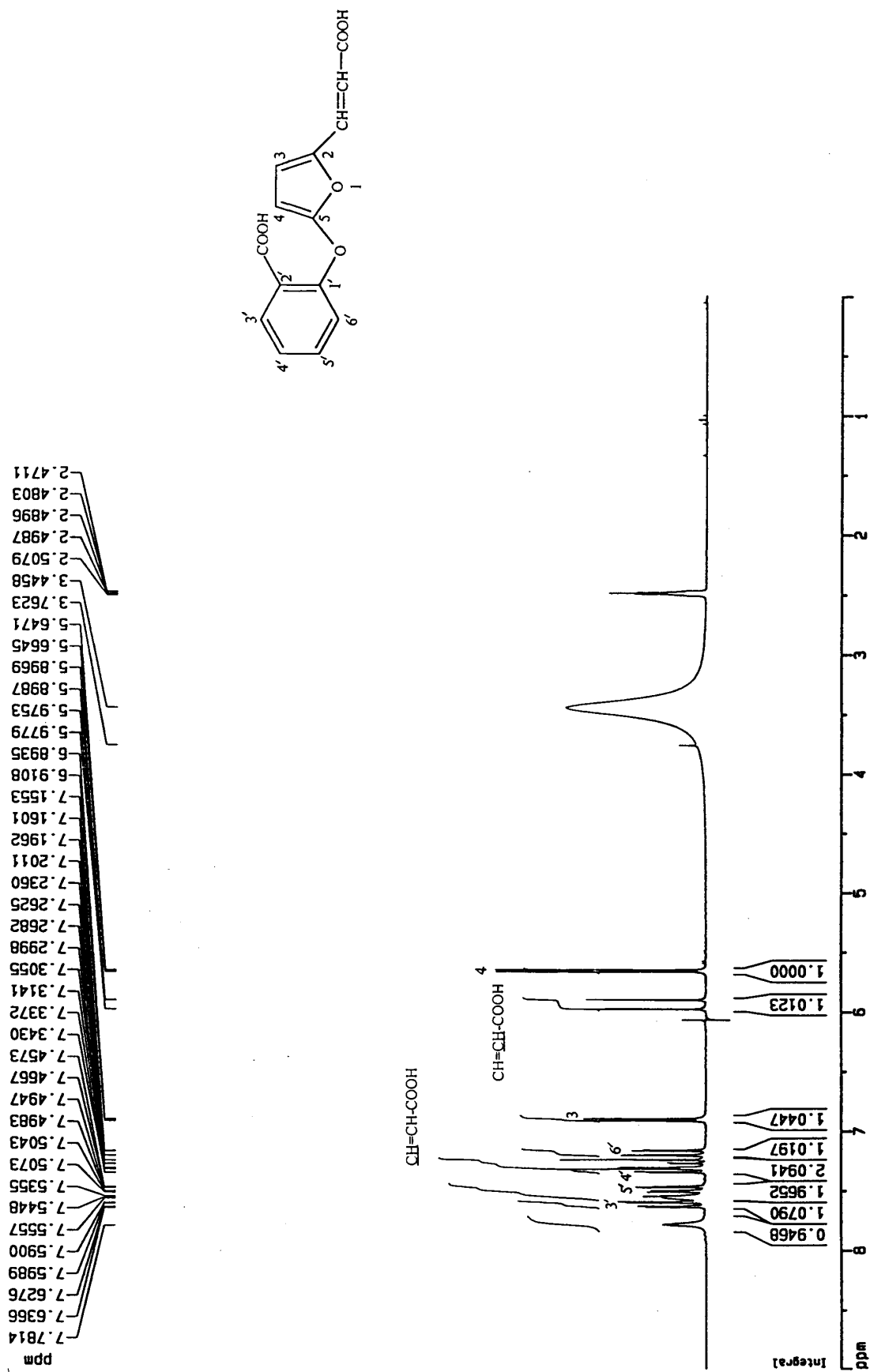

Figure 32. ¹H-NMR spectrum of compound 111

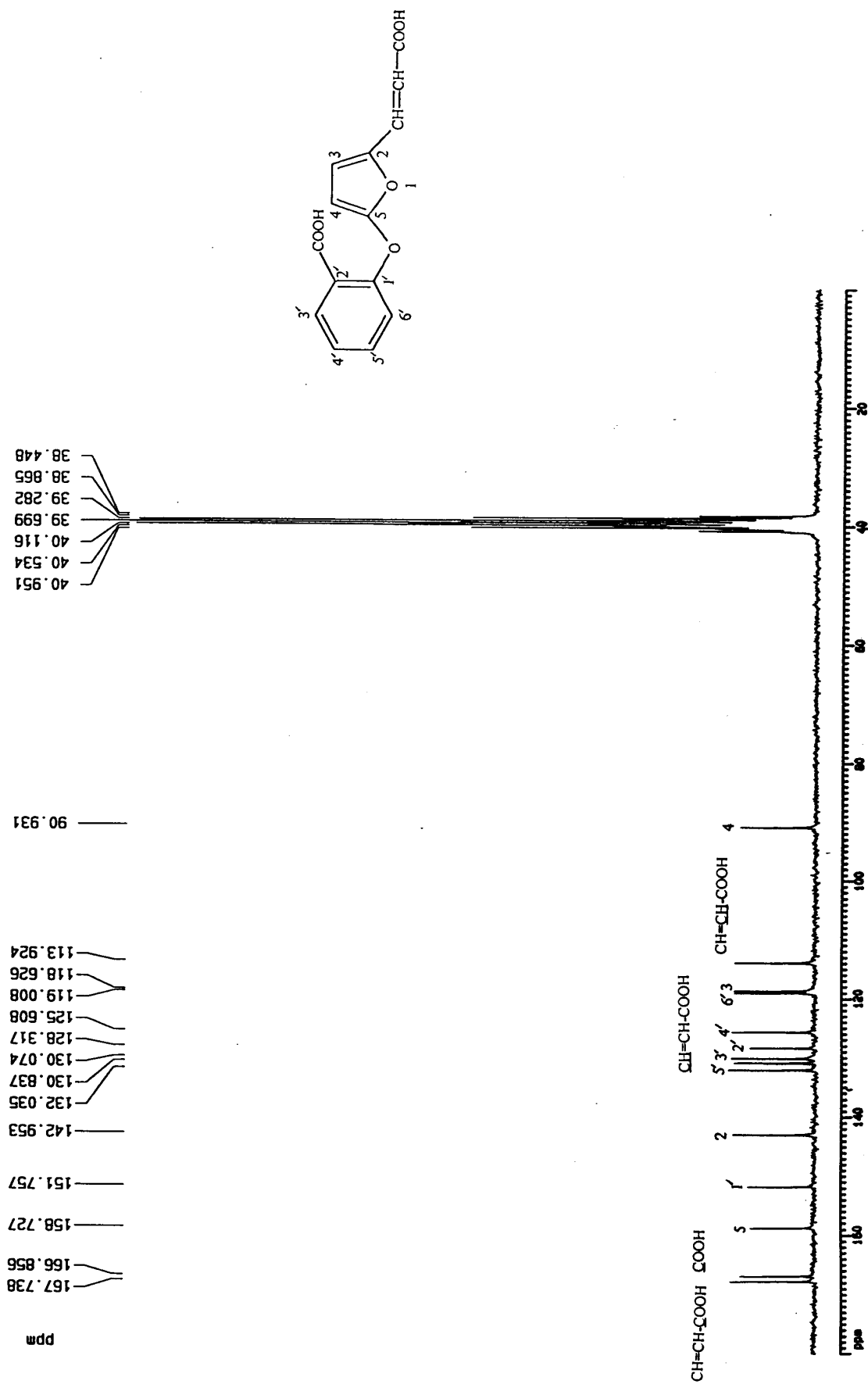

Figure 33. $^{13}\text{C-NMR}$ spectrum of compound 111

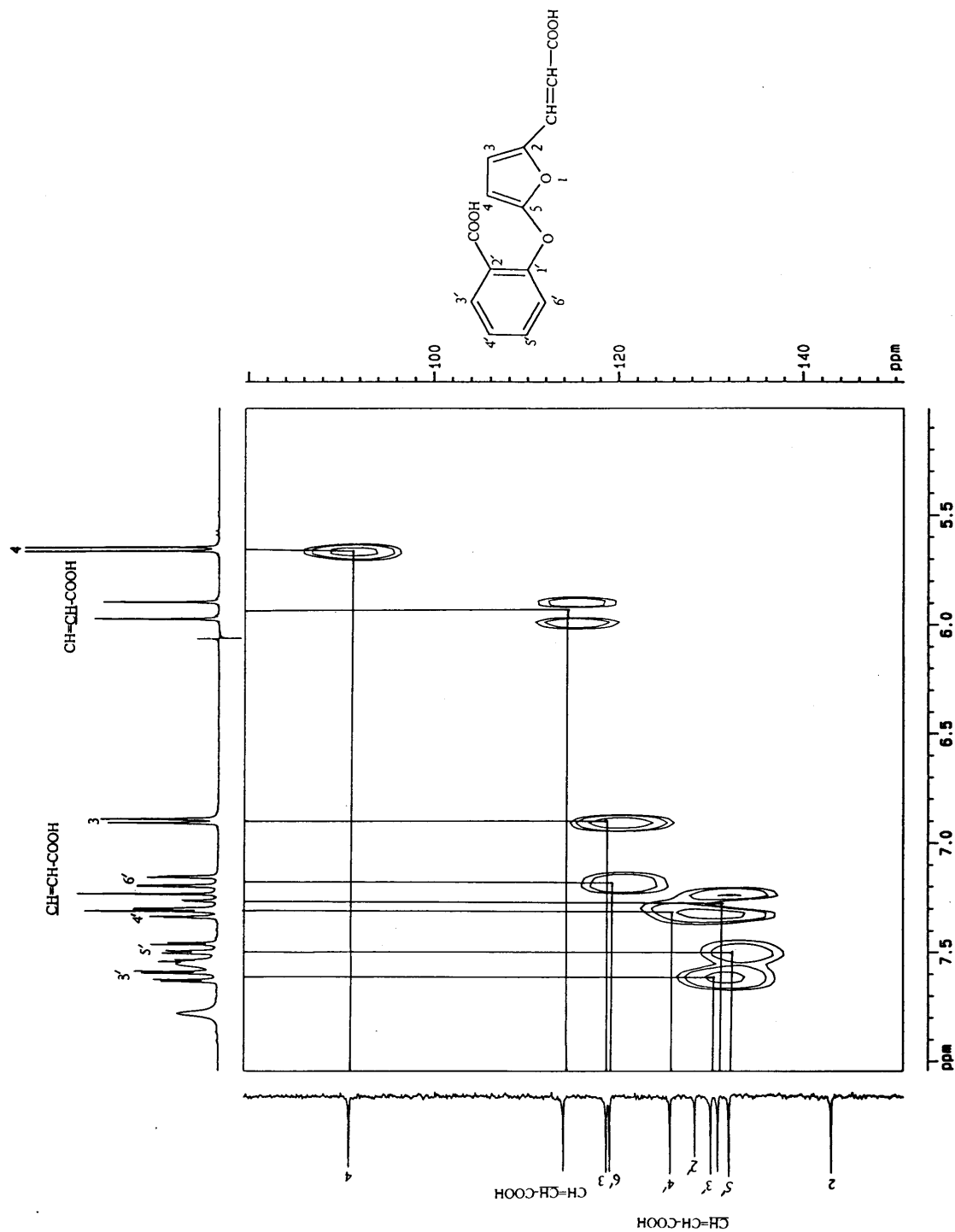

Figure 34. HMBC spectrum of compound 111

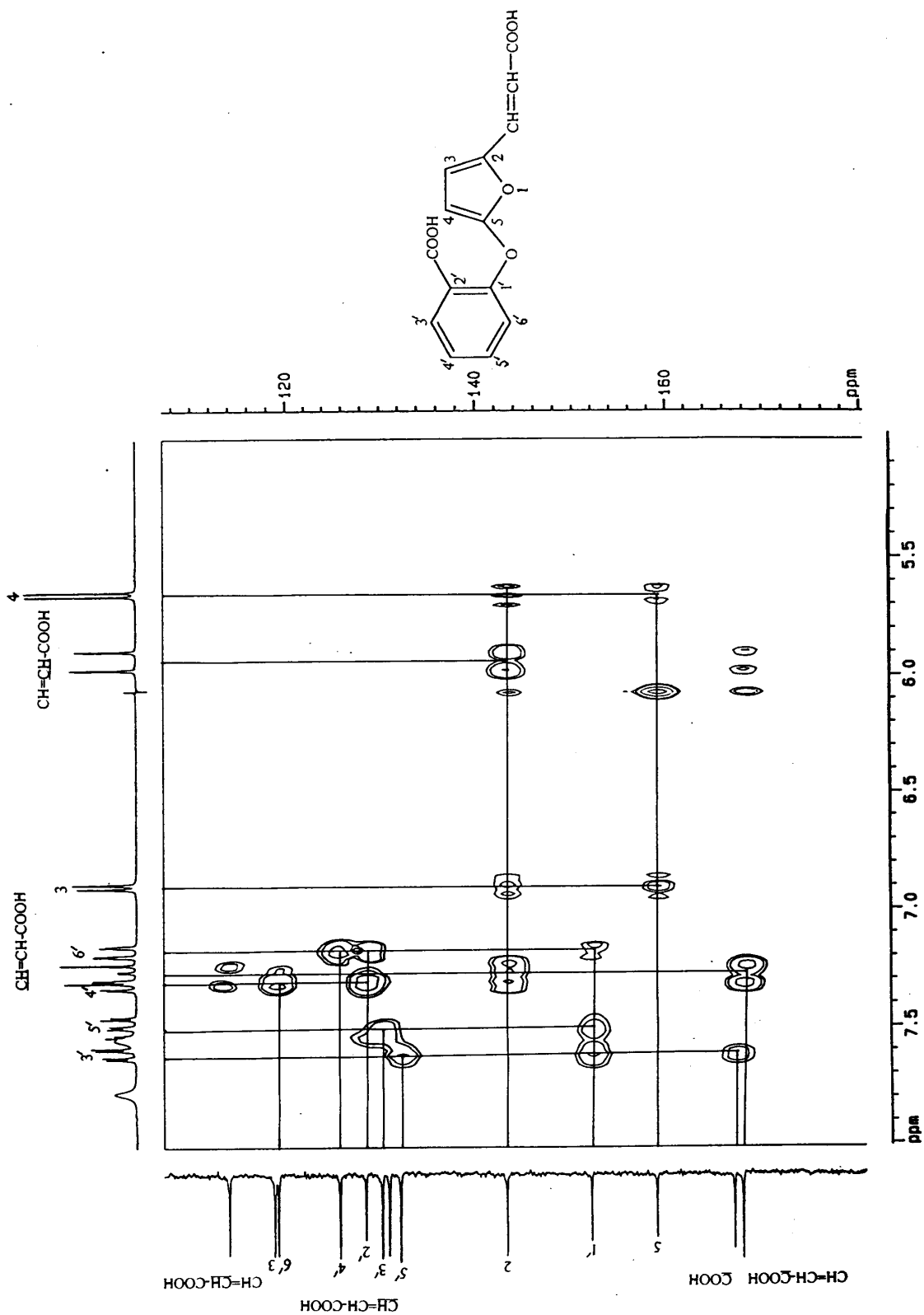

Figure 35. HMBC spectrum of compound 111

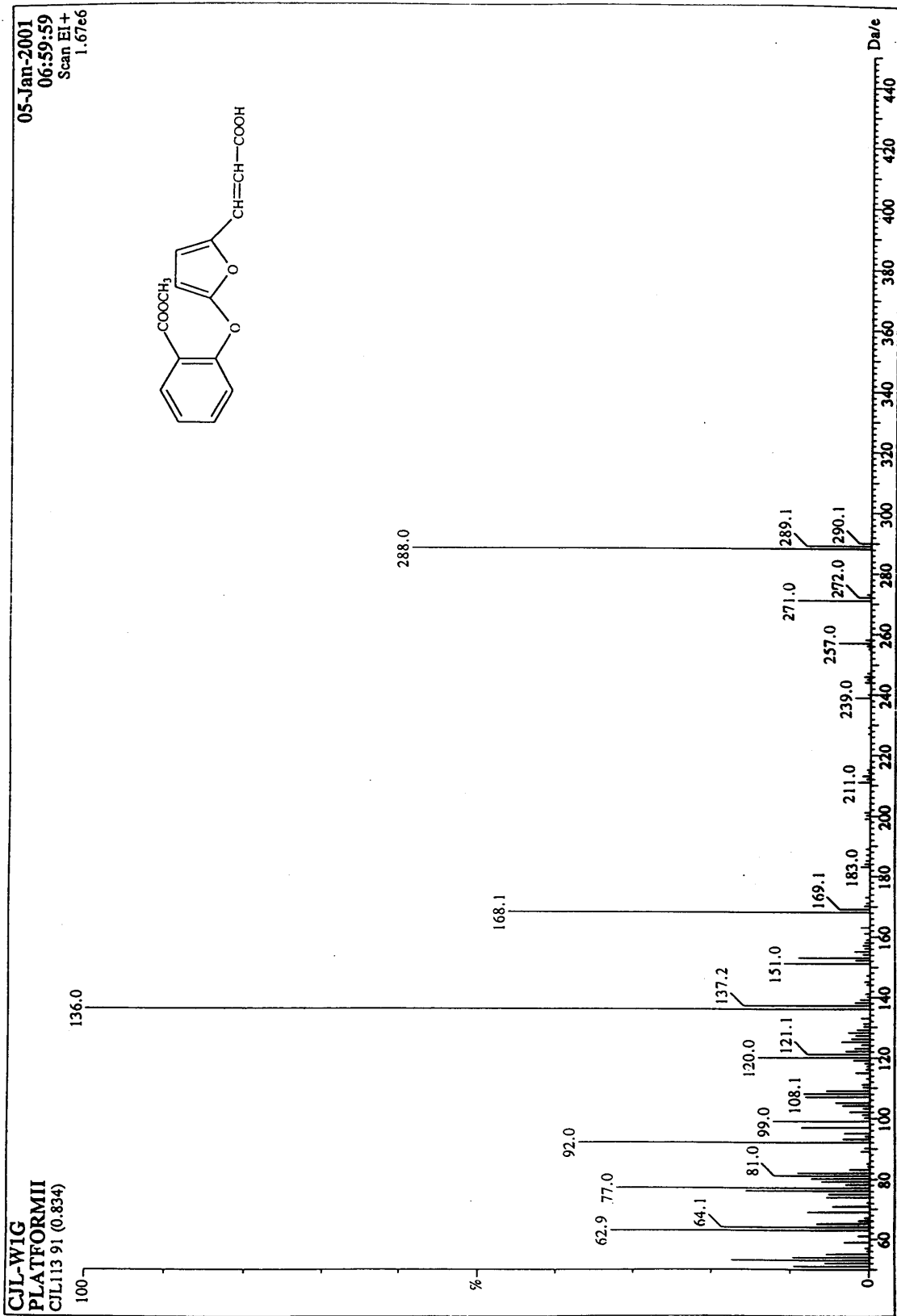

Figure 36. Mass spectrum of compound 101

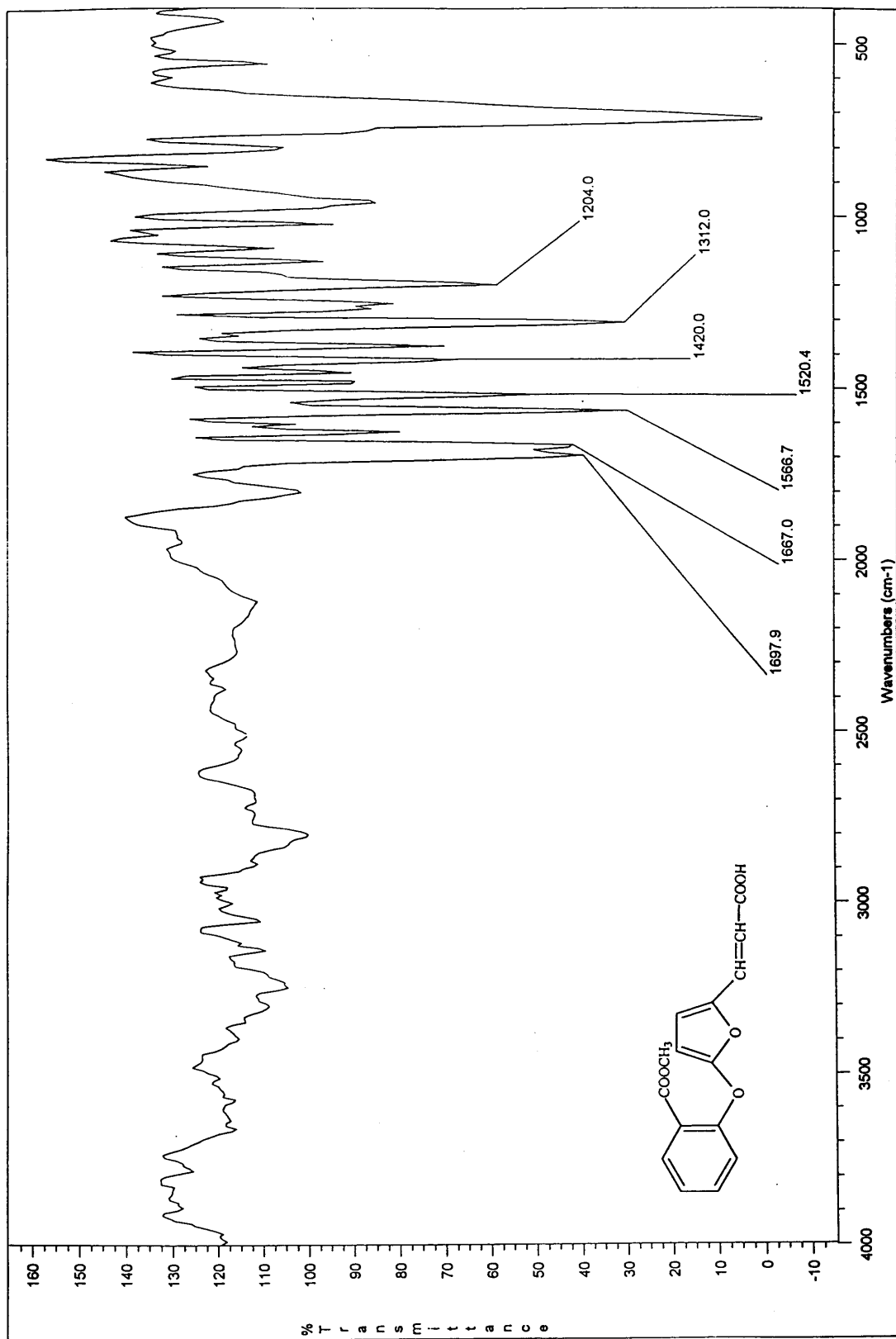

Figure 37. IR spectrum of compound 101

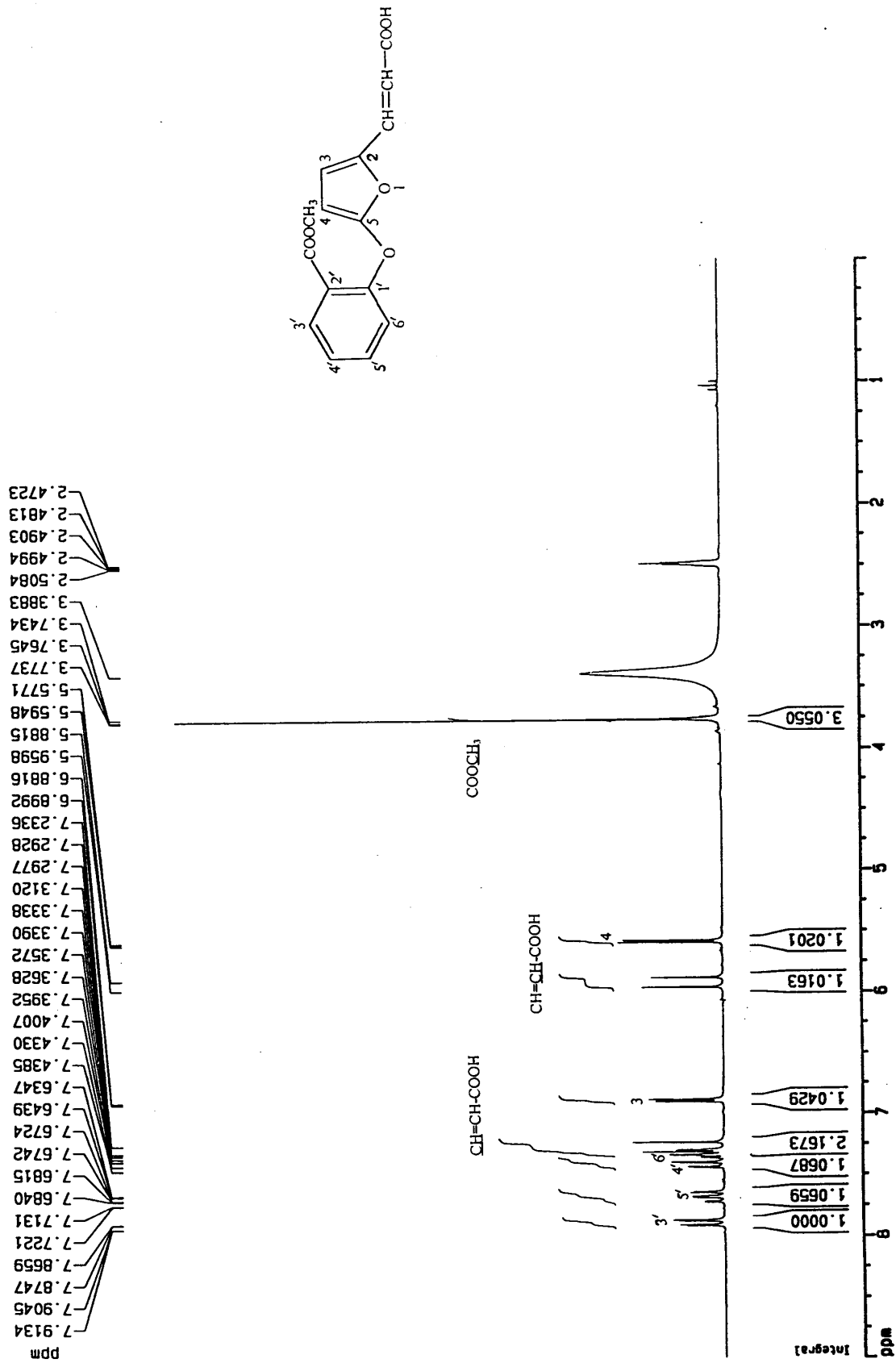

Figure 38. ¹H-NMR spectrum of compound 101

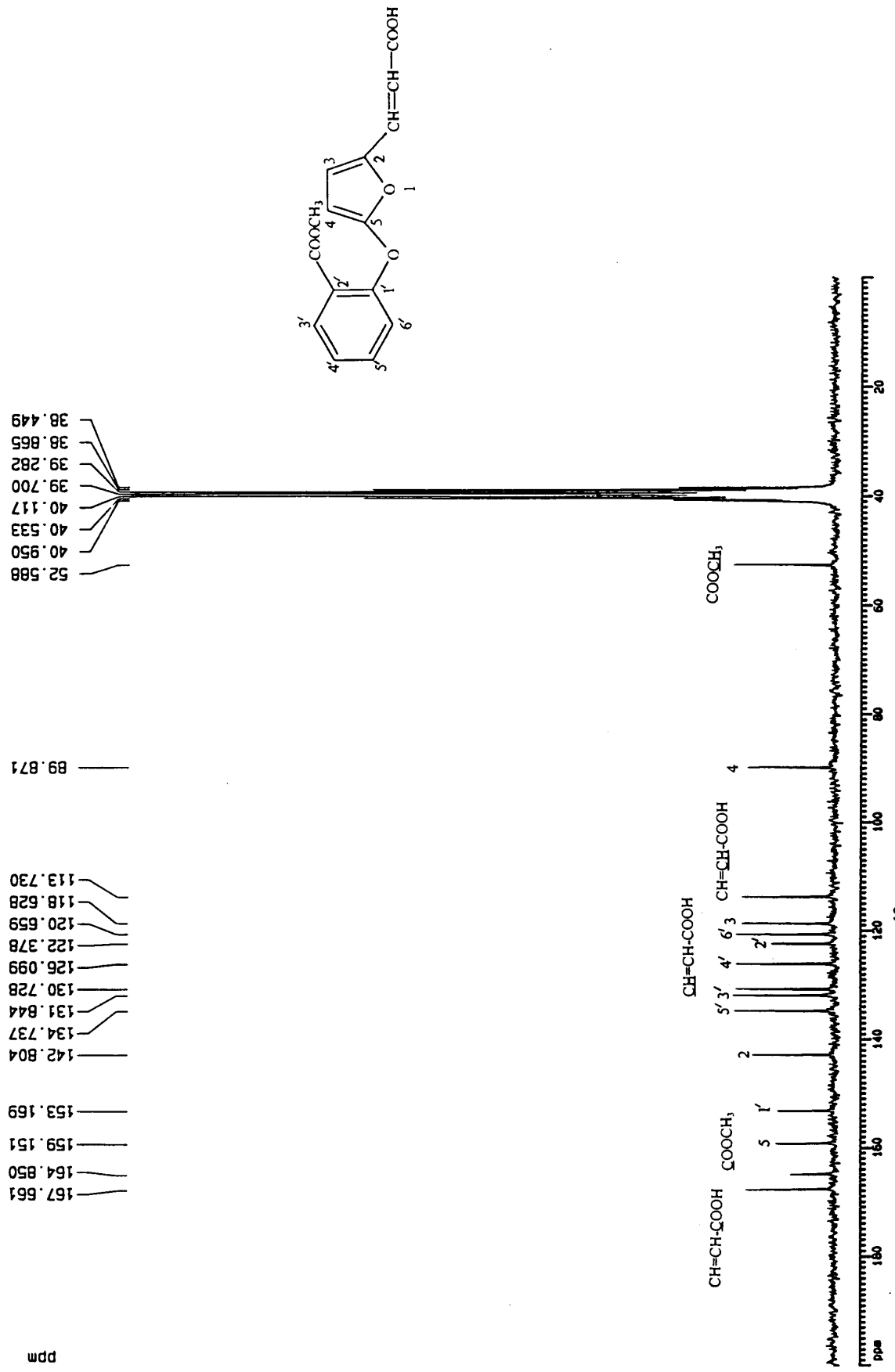

Figure 39. ¹³C-NMR spectrum of compound 101

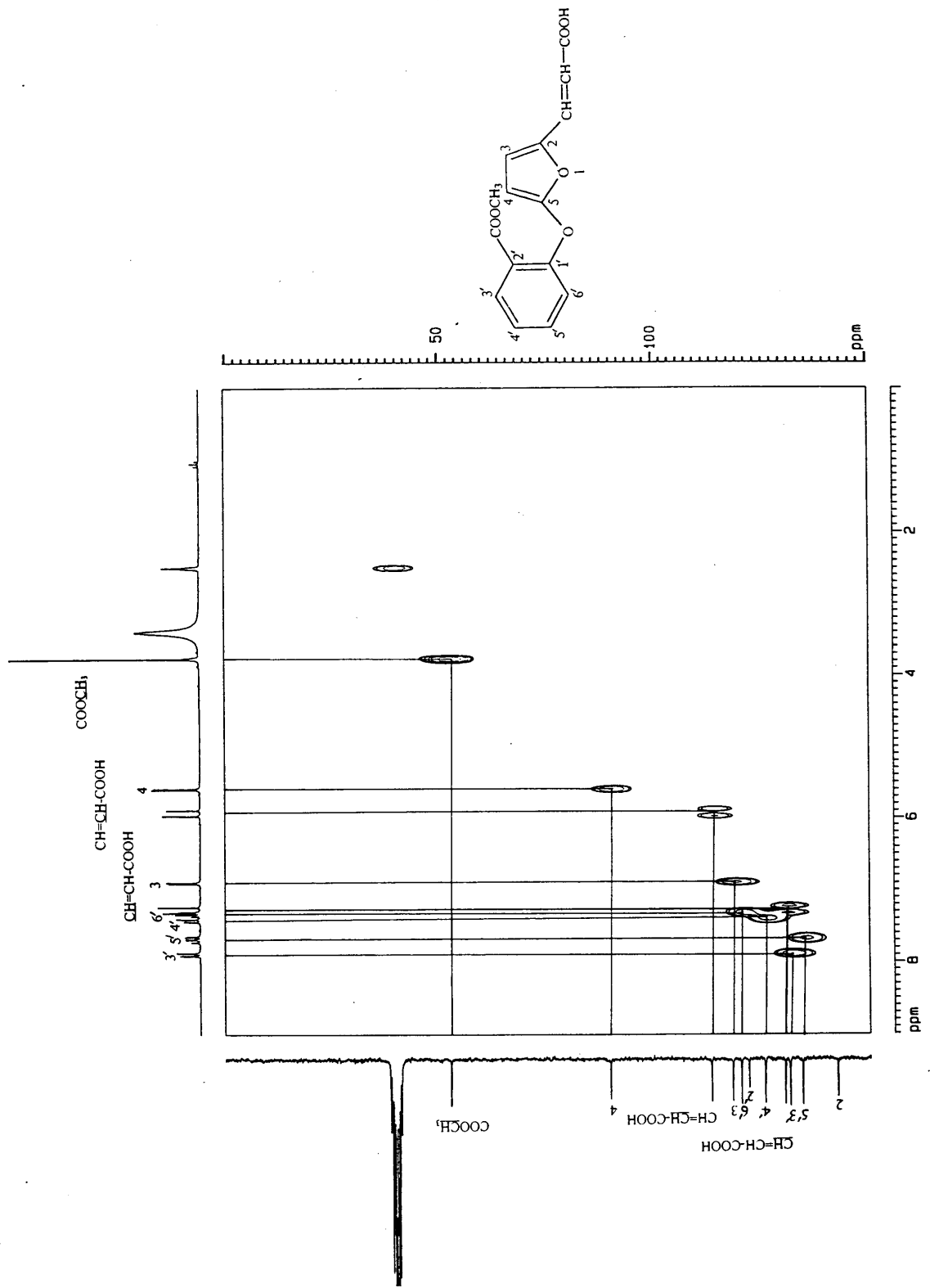

Figure 40. HMQC spectrum of compound 101

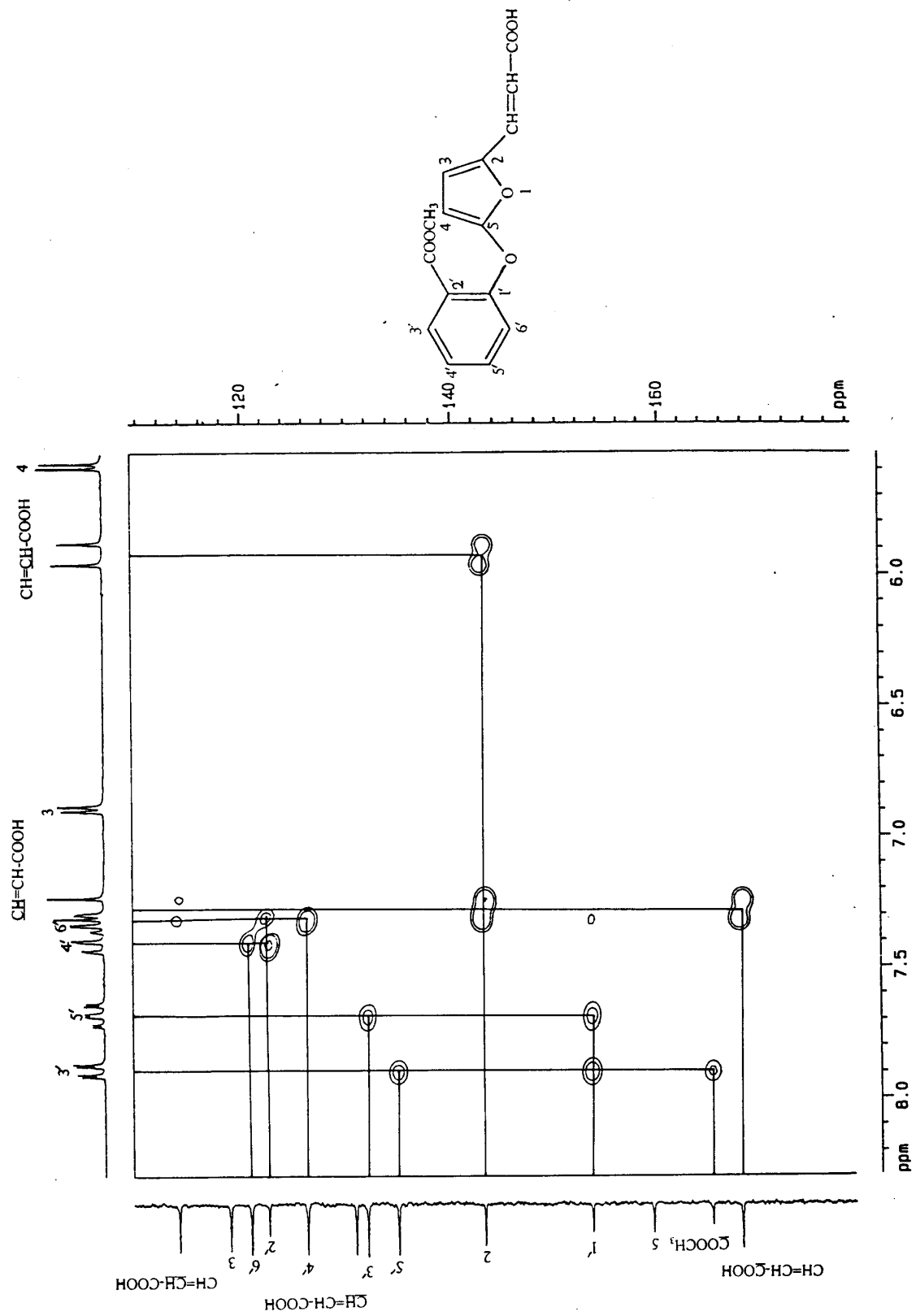

Figure 41. HMBC spectrum of compound 101

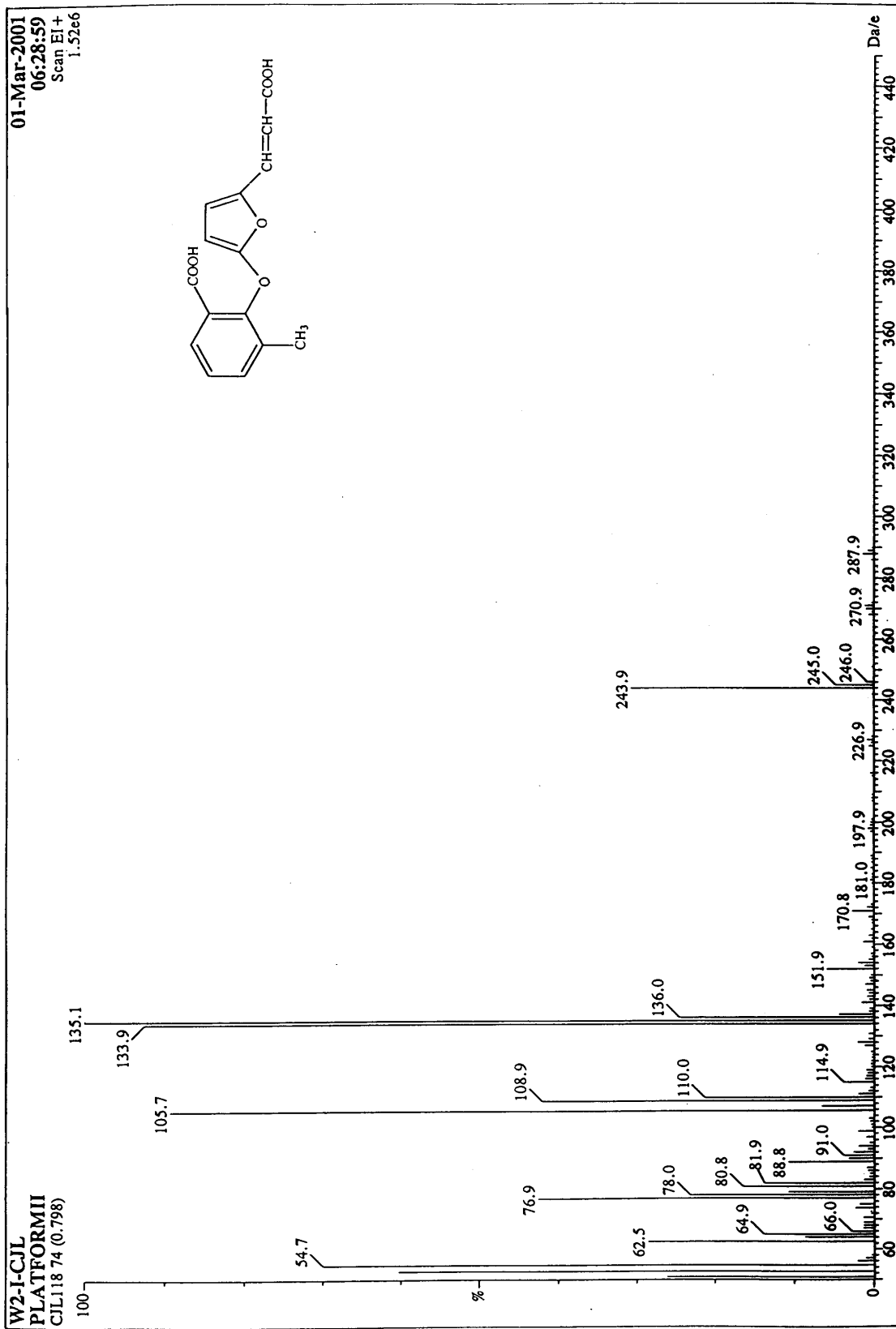

Figure 42. Mass spectrum of compound 112

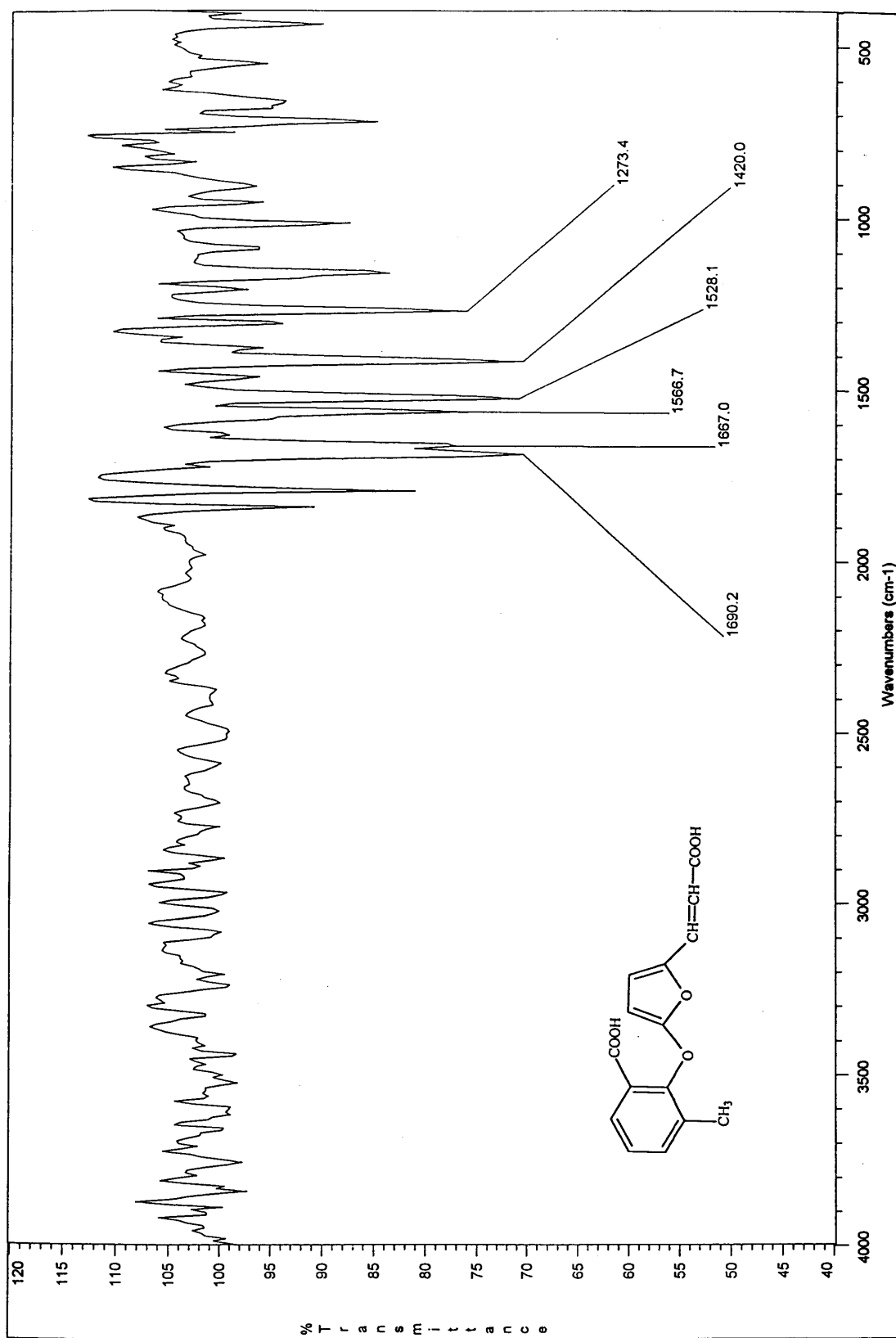

Figure 43. IR spectrum of compound 112

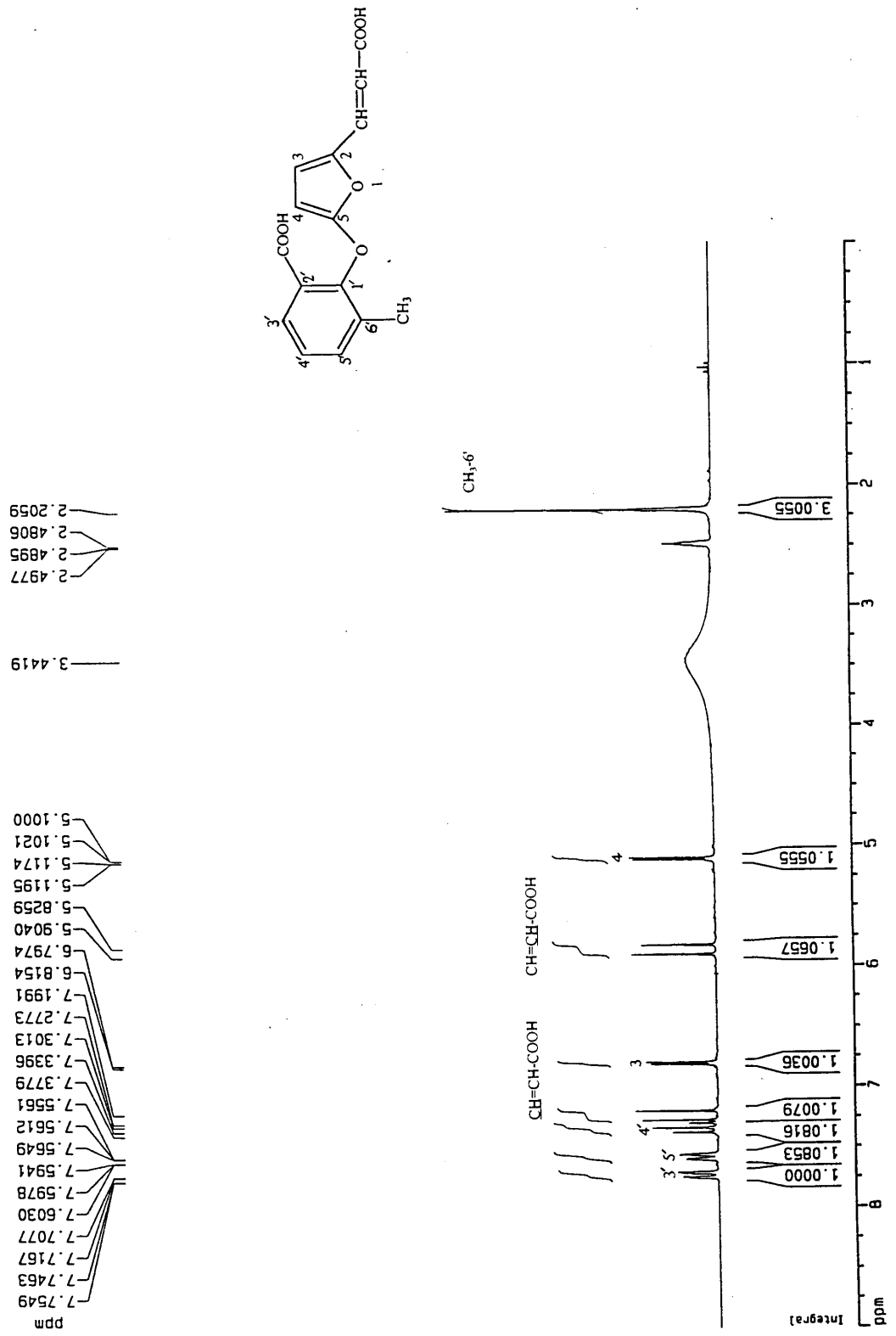

Figure 44. ¹H-NMR spectrum of compound 112

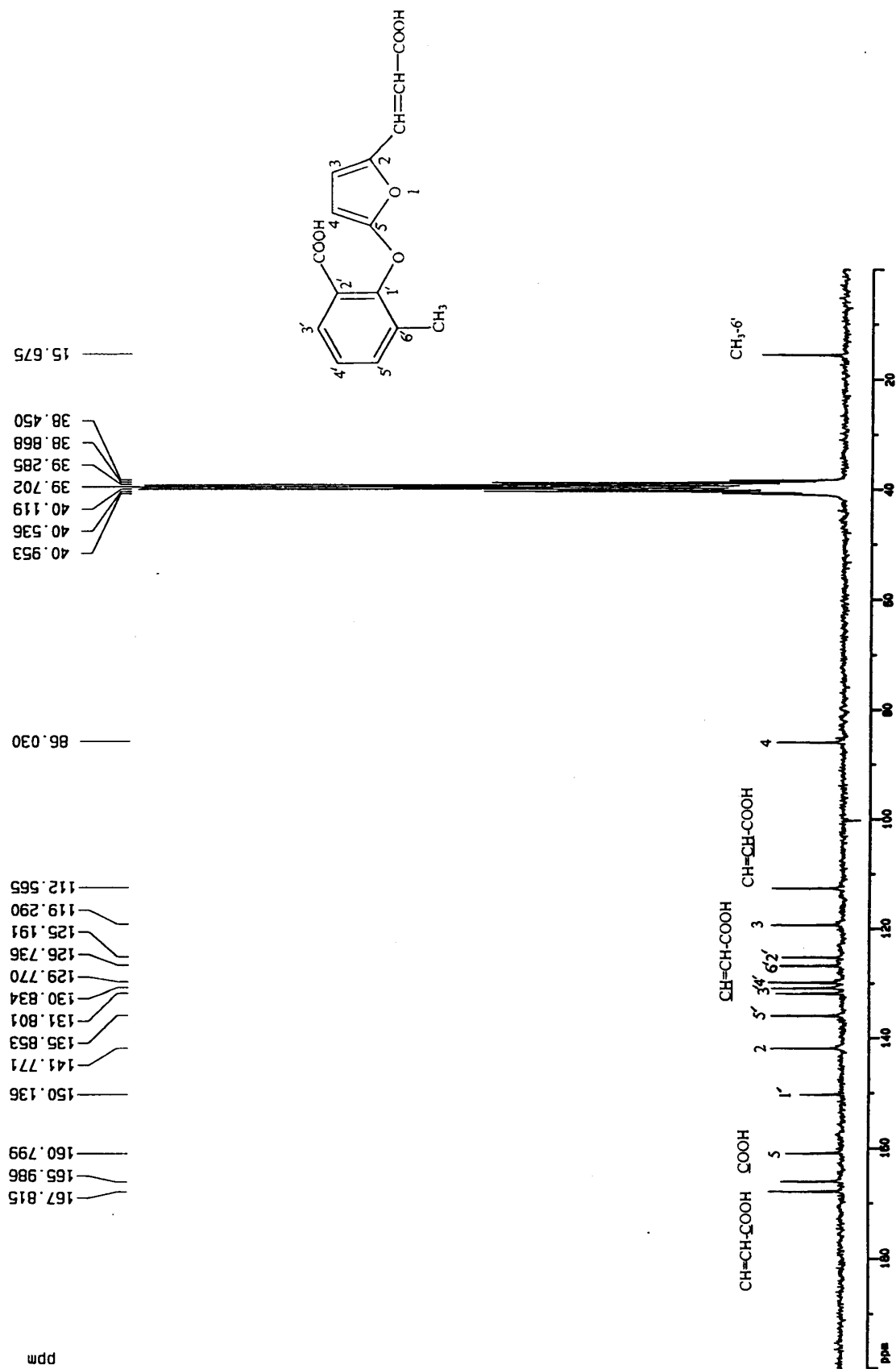

Figure 45. ¹³C-NMR spectrum of compound 112

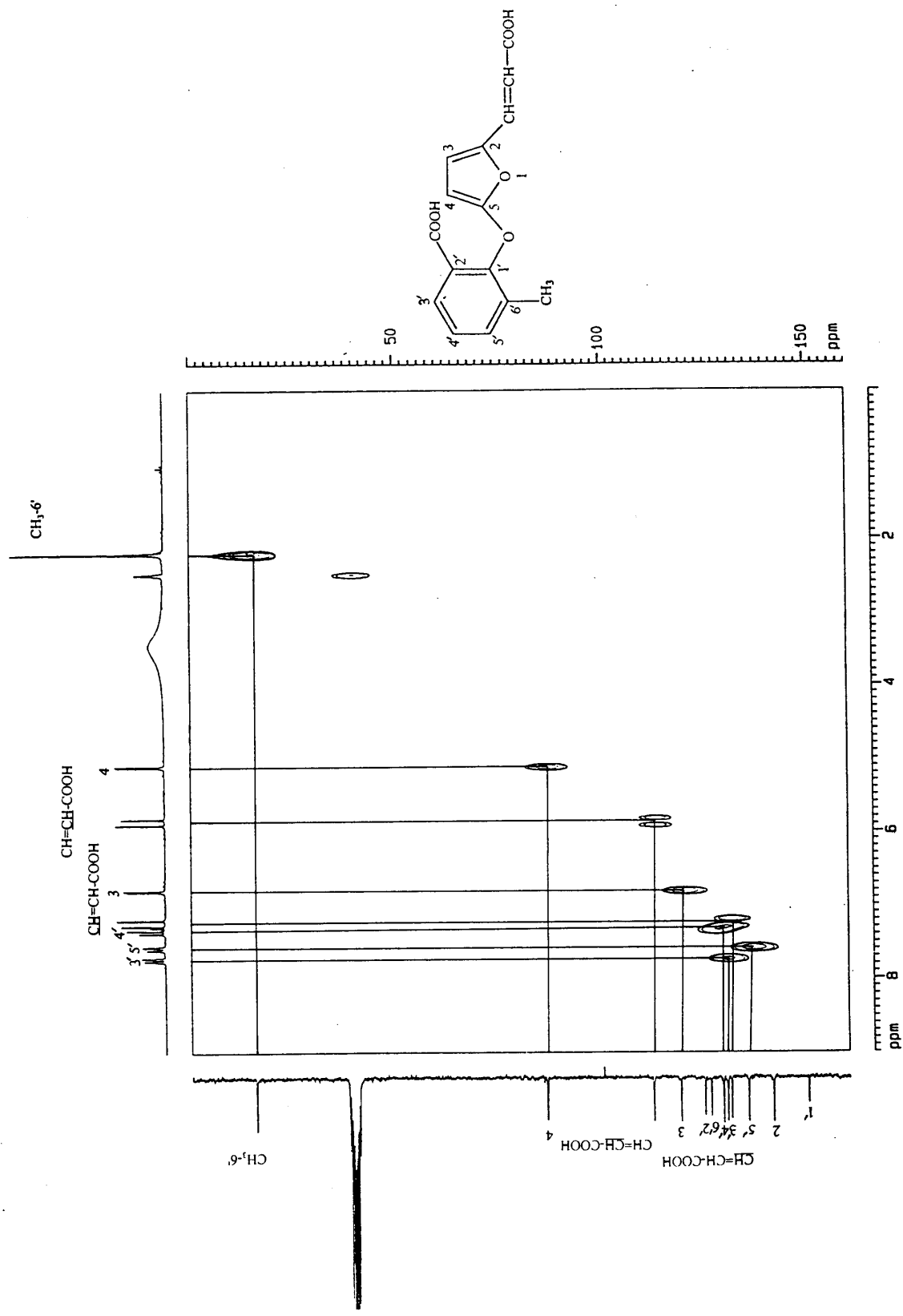

Figure 46. HMQC spectrum of compound 112